



ISOGROUND

Fixed Ground Mounting System

ASSEMBLY GUIDE

BNS-II-R-2V-SS



CONTENTS

• Required Tools	2
• Safety Instructions	3
• Tolerances	4
• Components	5-6
• Installation	7-13
• Maintenance	14
• Notes	15

REQUIRED TOOLS



Tape Measure

It is used to apply and control the dimensions specified in the assembly manual.



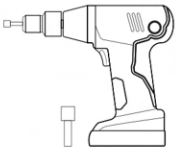

Marking

Necessary to mark the specified dimensions.



Electric Screwdriver

It is used to perform the assembly of the bolts used in the system.

-  6 mm
-  M10 15/17 mm
-  M12 18/19 mm



Torque Meter

It is used to ensure that the bolts used in the system are tightened at the desired torque value.

Measuring range ;

M8 : 14 -17 N.m

M10 : 40 - 50 N.m

M12 : 50 - 90 N.m



17-19 mm Wrench

It is used to perform the assembly of the bolts used in the system.



Allen

It is used to perform the assembly of the clamps used in the system.

-  6 mm

SAFETY EQUIPMENT



Protective Gloves



Goggles



Helmet



Protective Clothing



Safety Shoes

SAFETY INSTRUCTIONS

- Systems may only be assembled and commissioned by persons who can guarantee proper implementation based on their specialised suitability (e.g. training or profession) or experience.
- National and site-specific building codes, standards and environmental regulations must strictly be adhered to.
- Occupational safety and accident prevention regulations, relevant standards as well as regulations of professional associations must be complied with. The following must be particularly paid attention to:
 - Protective clothing must be worn (especially safety helmet, work boots and gloves).
 - Two persons must be present during the entire assembly process, in order to ensure rapid assistance in case of an accident.
 - The assembly instructions of the module manufacturer must be adhered to.
 - Equipotential bonding between individual system components must be performed in compliance with the respective national regulations.
 - During the entire assembly time it must be ensured that at least one copy of the assembly instruction is available at the construction site.
 - Failure to observe our installation regulations and installation instructions and non-use of all system components, as well as the installation and removal of components that were not purchased through us, results in us not being liable for any resulting defects or damage. In these cases our warranty will not be valid.
 - Components made of stainless steel are available in different corrosion resistance classes. In any case, it should be checked what corrosion load is expected for the building or component concerned. Z600 coated steel profiles may show red corrosion spots that do not affect static after a certain period of time.
 - In cases where material supplied by ISOTEC Enerji San. Ve Tic. Ltd. Şti. is re-cut to size on site, please ensure that the cut corners and edges are burr-free to rule out any risk of injury from sharp corners and edges.
 - In cases such as non-compliance with our general safety instructions or the installation of different components, ISOTEC Enerji San. and Tic. Ltd. Sti. has no liability.

TOLERANCES

1 - Pile Tolerances

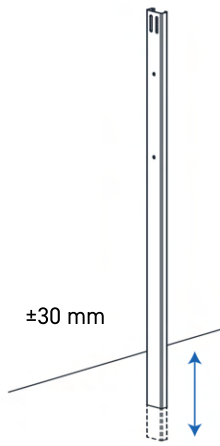

$\pm 30 \text{ mm}$ for Z axis

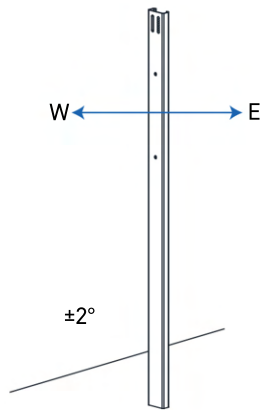

For East - West slope

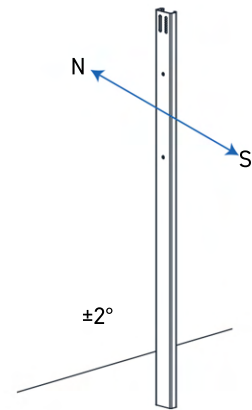

For the slope in the North - South direction

2 - Implementation Tolerances

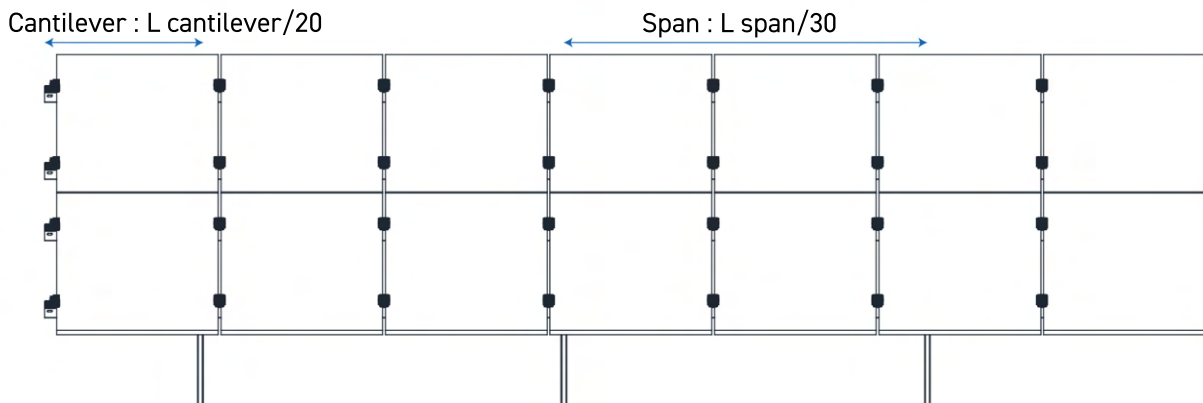

3 - Table Slope Tolerances

East - West max. installable slope 4°
South - South max installable slope 25°

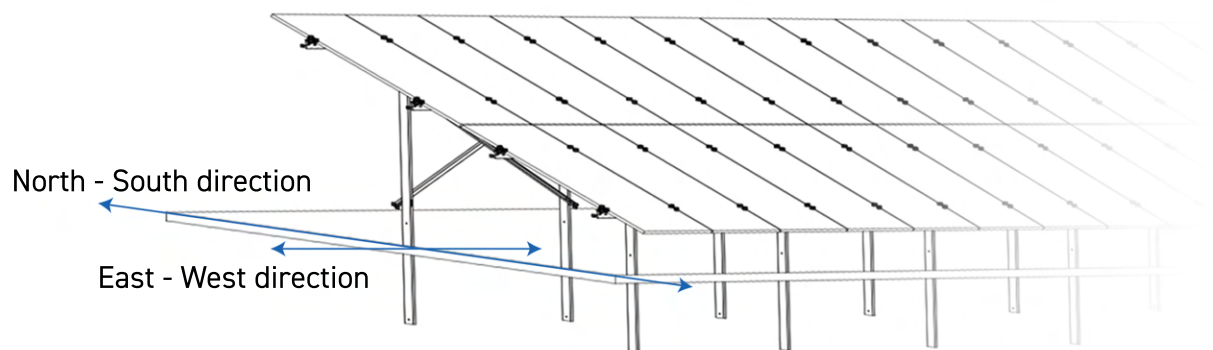

COMPONENTS

1. Front Pile



2. Rear Pile



3. Beam



4. Purlin



5. Brace E - W

Optional, used in earthquake zones when necessary



6. Brace N - S

Optional, used in high wind zones when necessary



COMPONENTS

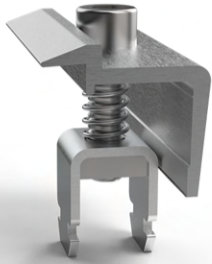

7. EasyClamp End

Panel holder clamp set
Compatible with framed PV modules of 30 - 40 mm height.



8. EasyClamp Mid

Panel holder clamp set
Compatible with framed PV modules of 30 - 40 mm height.

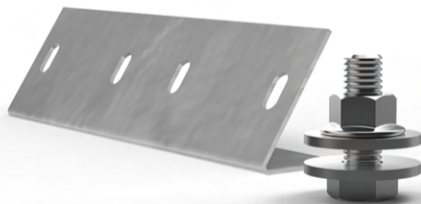

9.Connector

It is used to join steel purlins.

INSTALLATION

Pile - Beam Assembly

- 1. 2 x M10 x 30 Hex Bolt
- 2. 4 x M10 Washer
- 3. 2 x M10 Nut

OR

- 1. 2 x M12 x 30 Hex Bolt
- 2. 4 x M12 Washer
- 3. 2 x M12 Nut

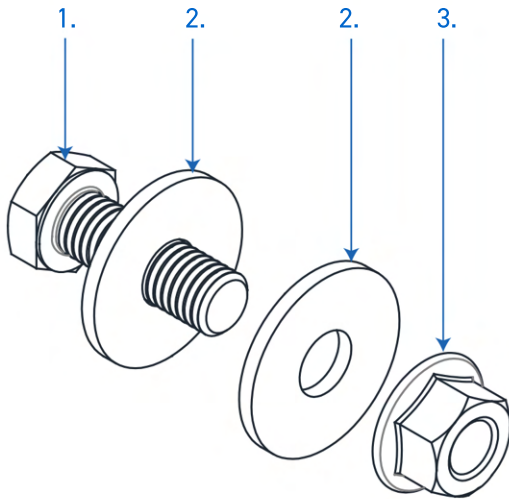

Torque values

Bolt Size	Quality	Coating	Torque (N.m)
M10	8.8	Zinc	48 - 50
M10	A2 - 70	Stainless	38 - 42
M12	8.8	Zinc	80 - 90

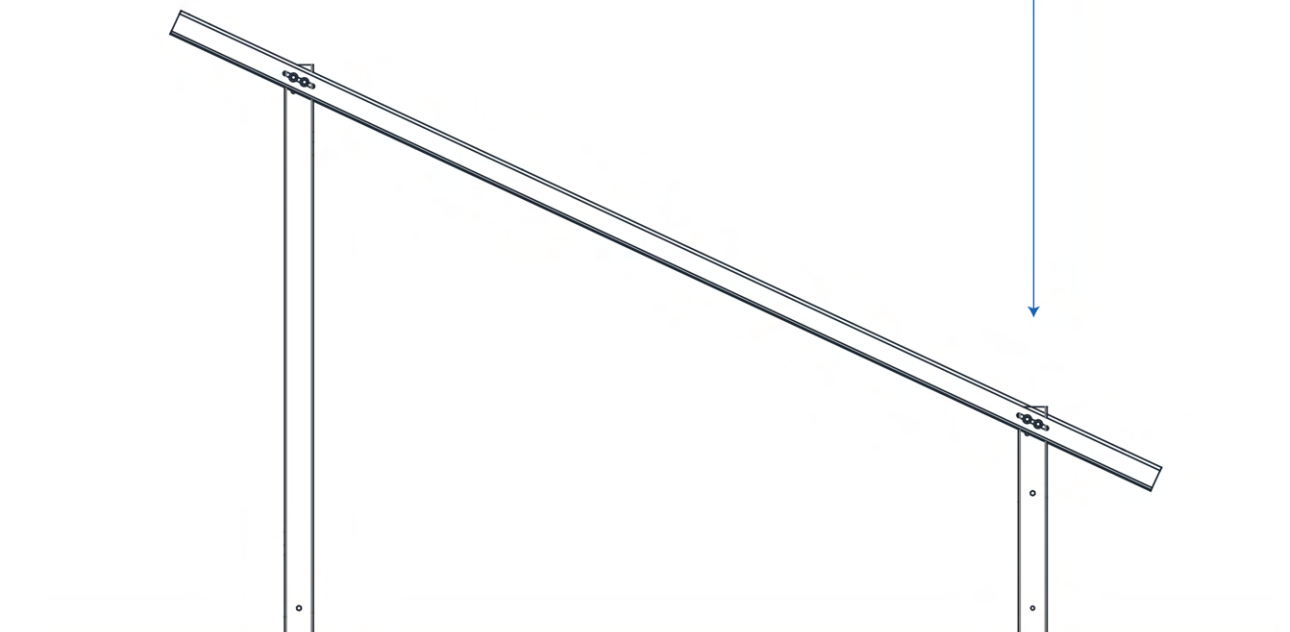
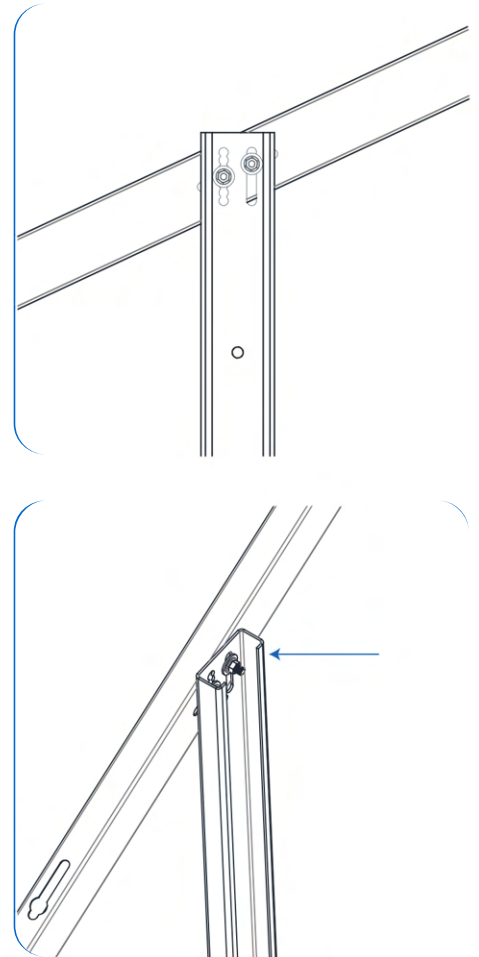

INSTALLATION

Beam - Purlin Assembly

- 1. M10x25 Hex Bolt
- 2. M10 Washer
- 3. M10 Nut

OR

- 1. M12x25 Hex Bolt
- 2. M12 Washer
- 3. M12 Nut

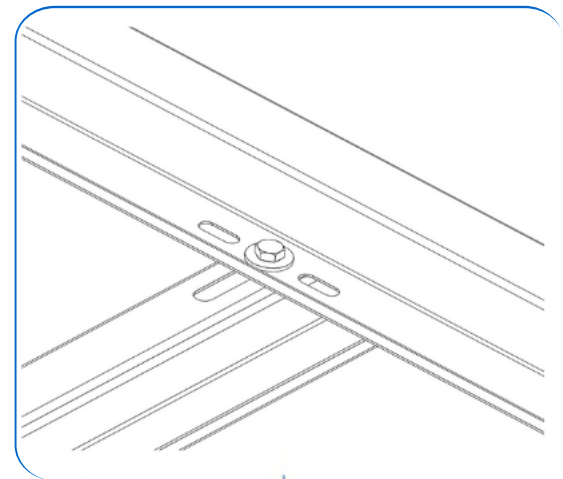
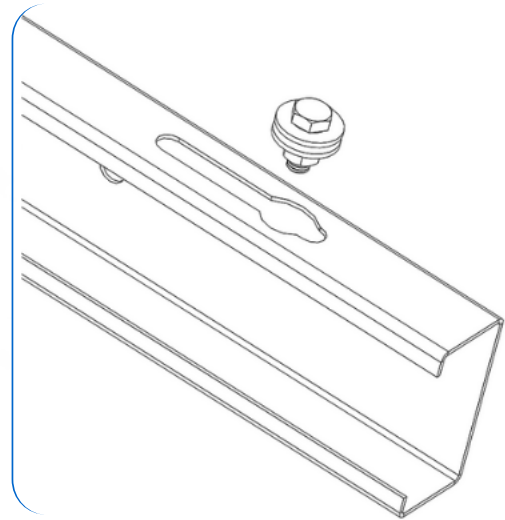
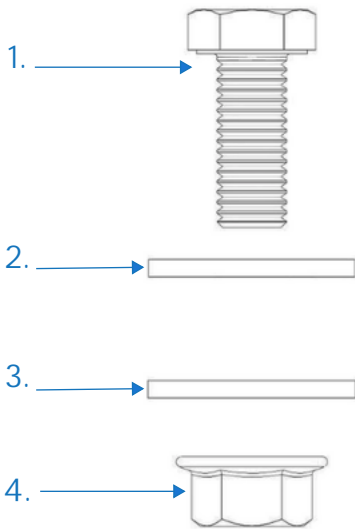

Torque values

Bolt Size	Quality	Coating	Torque (N.m)
M10	8.8	Zinc	48 - 50
M10	A2 - 70	Stainless	38 - 42
M12	8.8	Zinc	45 - 50

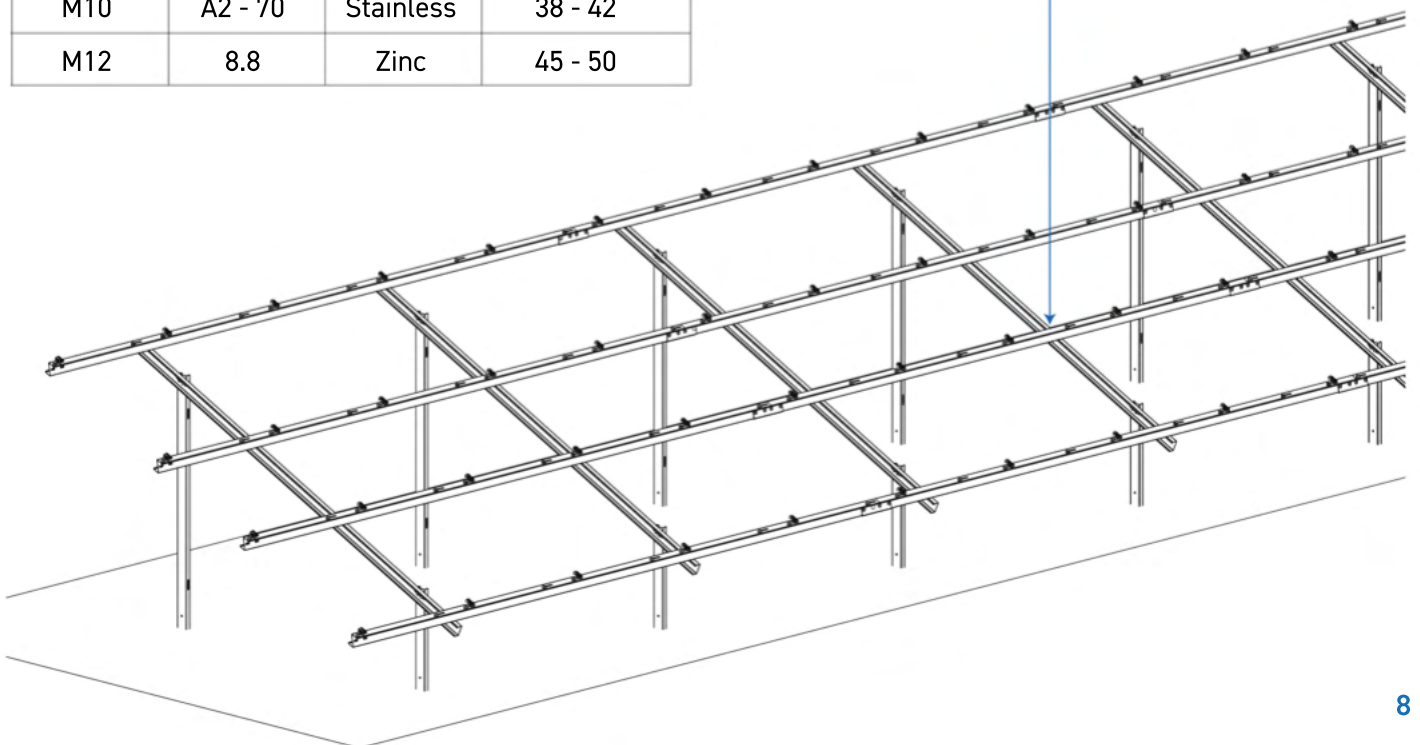

INSTALLATION

Purlin - Connector

- 1. 4 x M10 x 30 Hex Bolt
- 2. 8 x M10 Washer
- 3. 4 x M10 Nut

OR

- 1. 4 x M12 x 30 Hex Bolt
- 2. 8 x M12 Washer
- 3. 4 x M12 Nut

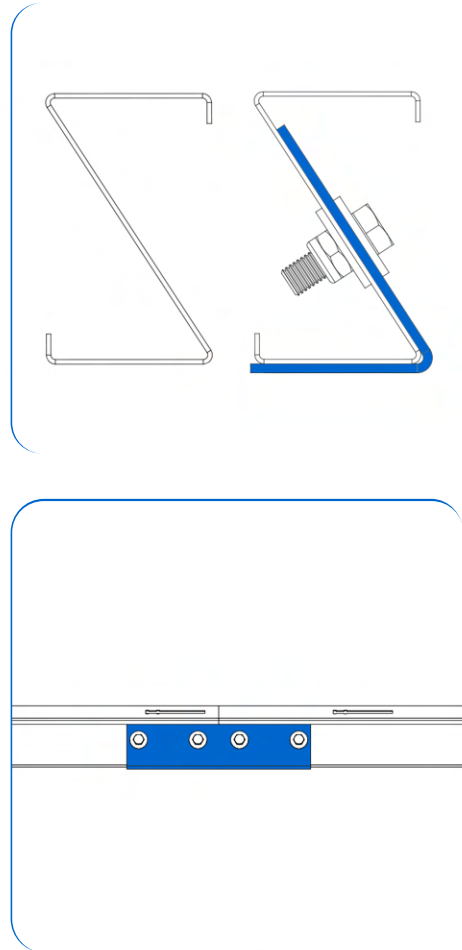
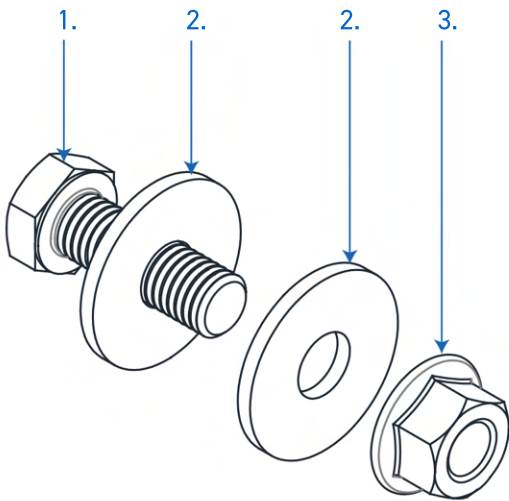

Torque values

Bolt Size	Quality	Coating	Torque (N.m)
M10	8.8	Zinc	48 - 50
M10	A2 - 70	Stainless	38 - 42
M12	8.8	Zinc	80 - 90

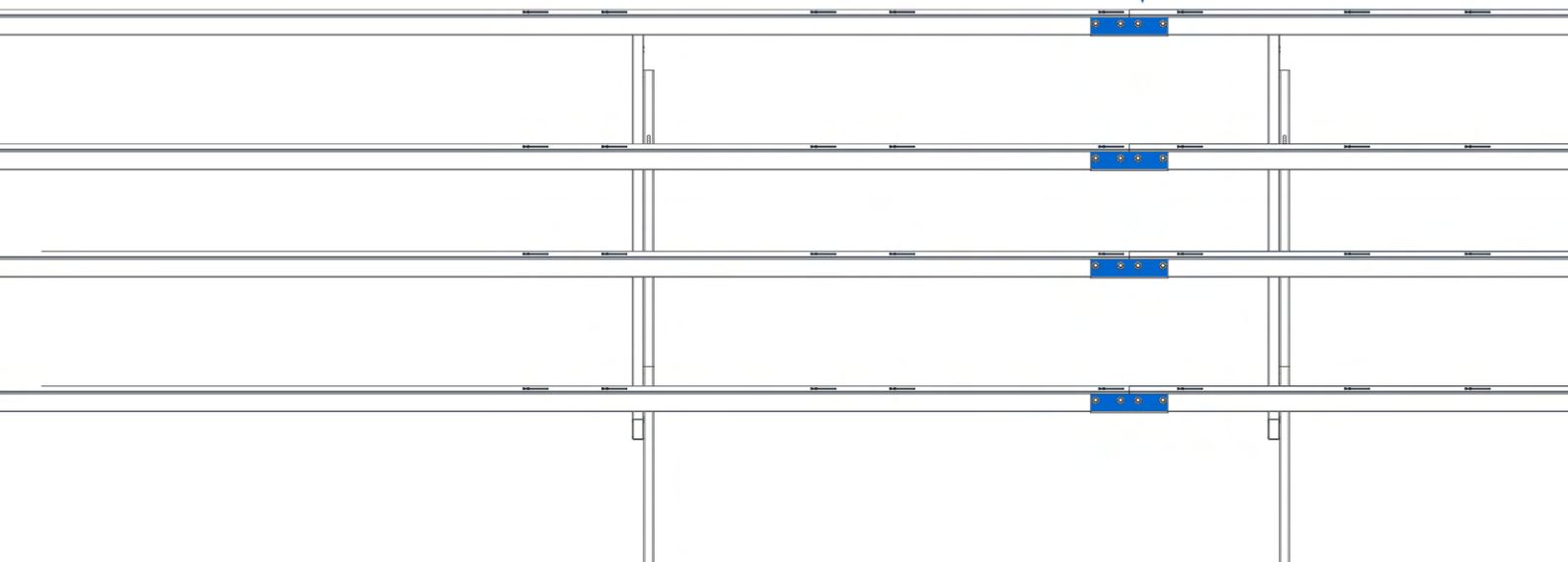

INSTALLATION

Rear Pile - Brace E - W Assembly

- | | | |
|--------------------------|----|--------------------------|
| 1. 2 x M10 x 30 Hex Bolt | | 1. 2 x M12 x 30 Hex Bolt |
| 2. 2 x M10 Washer | OR | 2. 2 x M12 Washer |
| 3. 2 x M10 Nut | | 3. 2 x M12 Nut |

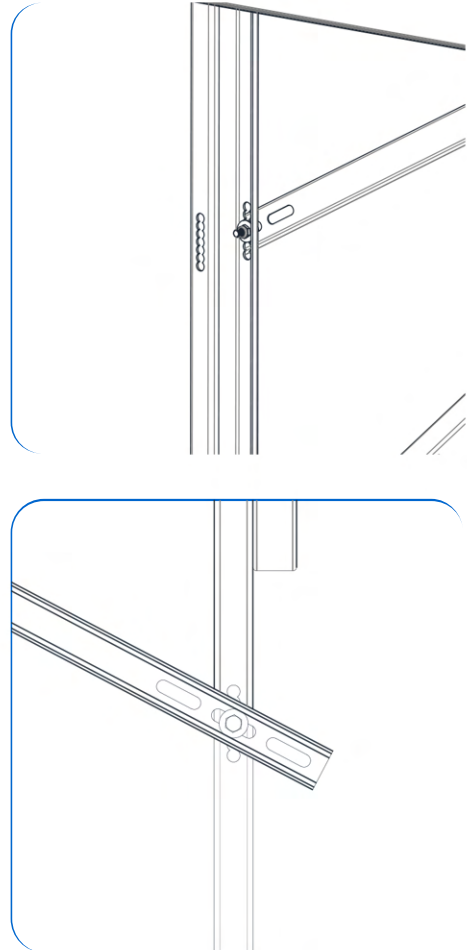
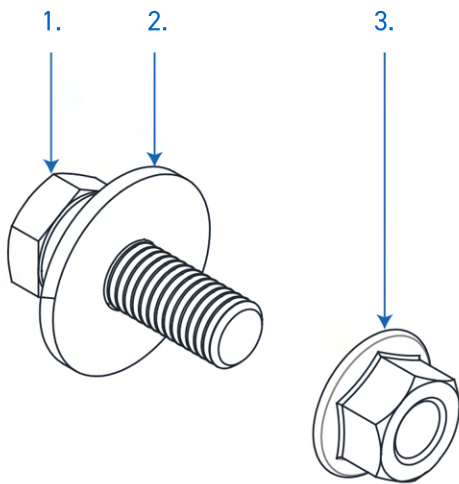

Torque values

Bolt Size	Quality	Coating	Torque (N.m)
M10	8.8	Zinc	48 - 50
M10	A2 - 70	Stainless	38 - 42
M12	8.8	Zinc	80 - 90

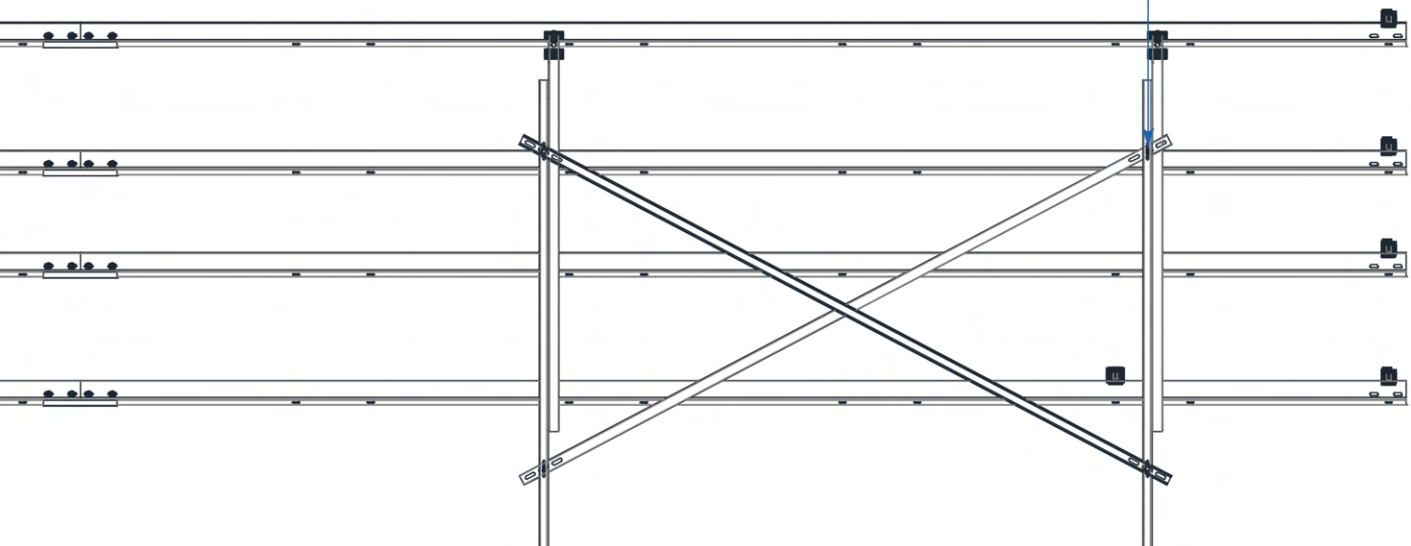

INSTALLATION

Front Pile - Rear Pile - Brace N - S Assembly

- 1. 2 x M10 x 30 Hex Bolt
 - 2. 2 x M10 Washer
 - 3. 2 x M10 Nut
- OR
- 1. 2 x M12 x 30 Hex Bolt
 - 2. 2 x M12 Washer
 - 3. 2 x M12 Nut

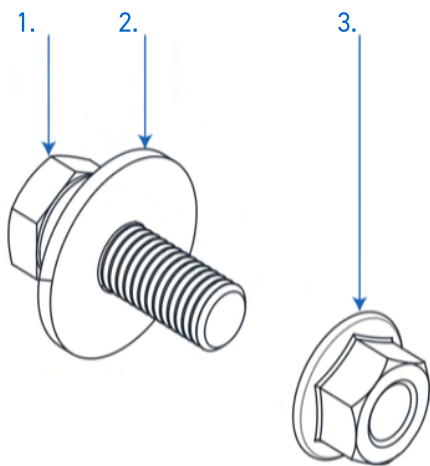

The bolt and washer should be on the slotted hole side

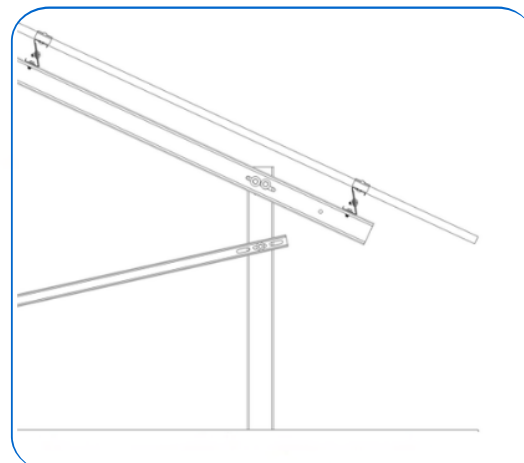

Torque values

Bolt Size	Quality	Coating	Torque (N.m)
M10	8.8	Zinc	48 - 50
M10	A2 - 70	Stainless	38 - 42
M12	8.8	Zinc	80 - 90

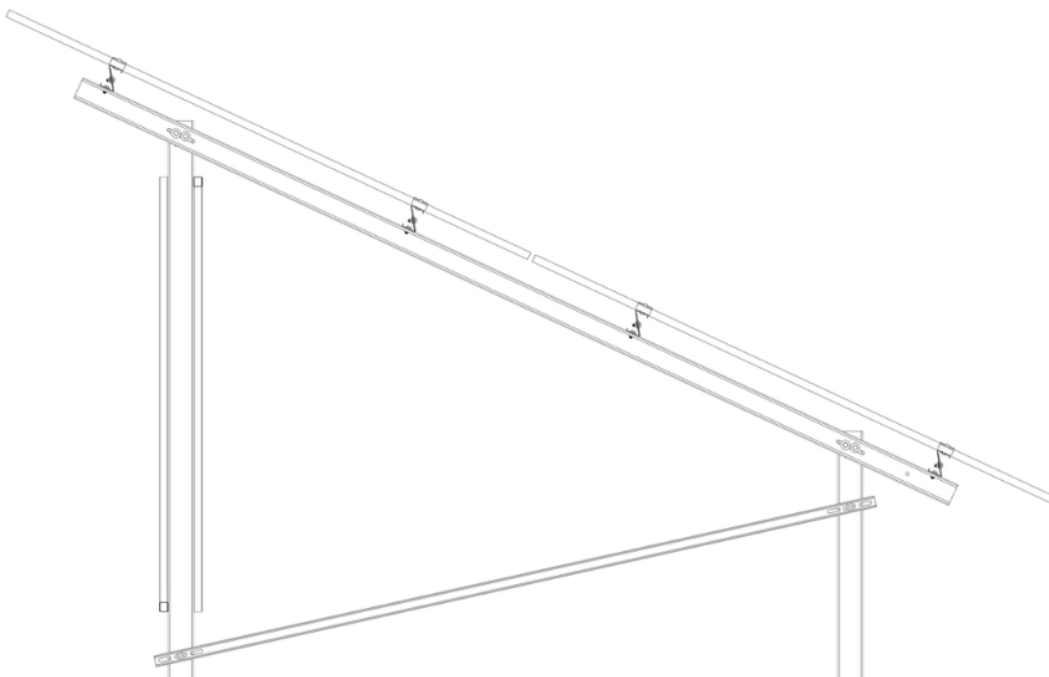

INSTALLATION

Purlin - Mid Clamp Assembly

Torque value (N.m) : 14 - 18

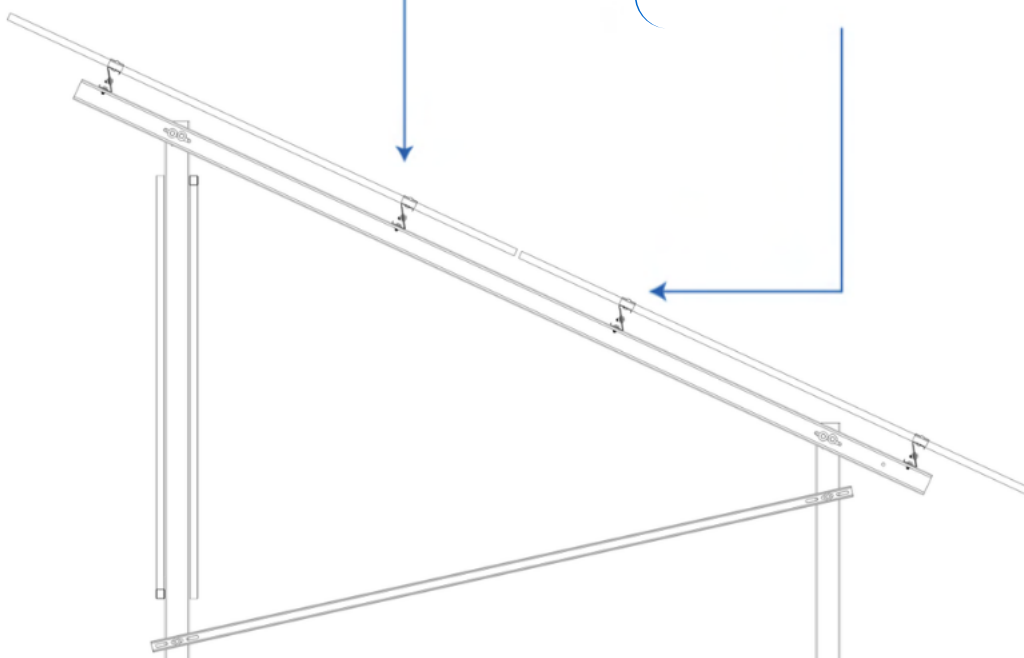
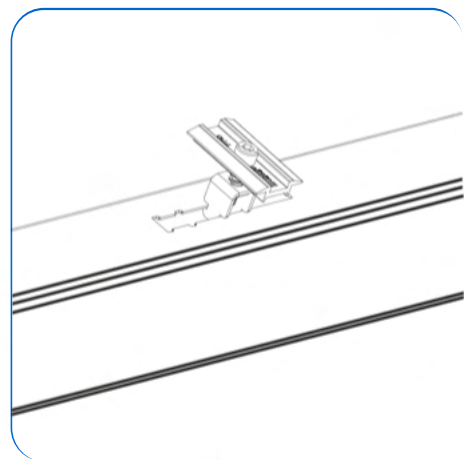
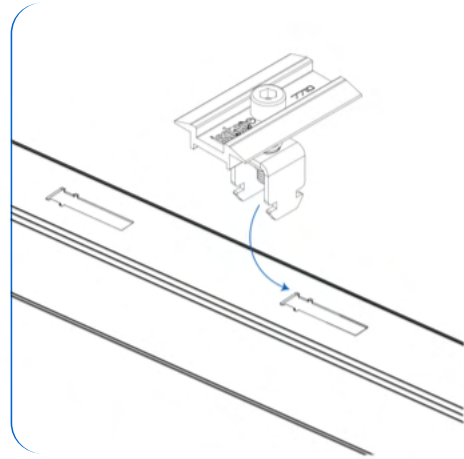
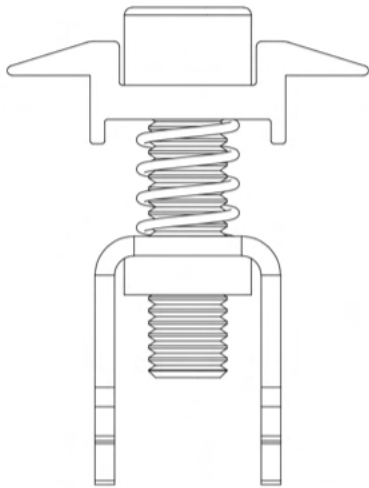

INSTALLATION

Purlin - End Clamp Assembly

Torque value (N.m) : 14 - 18

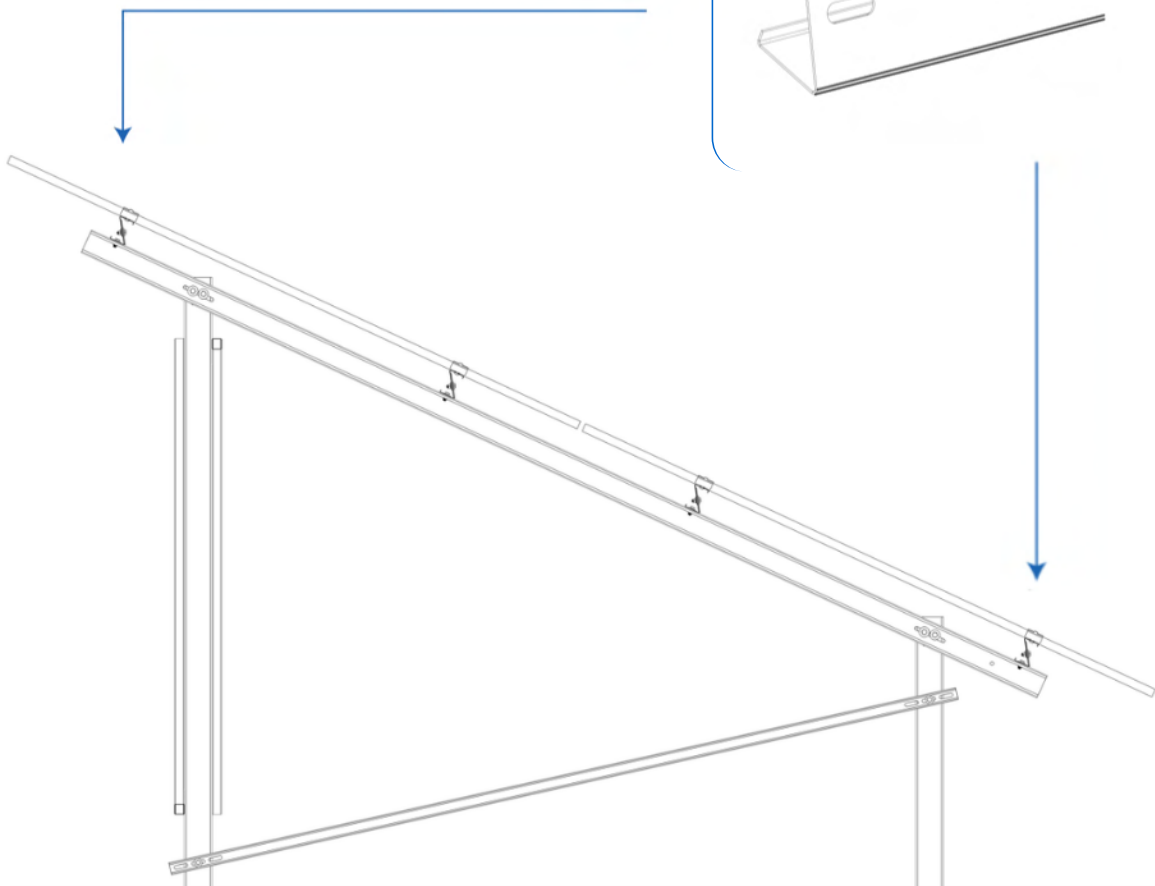
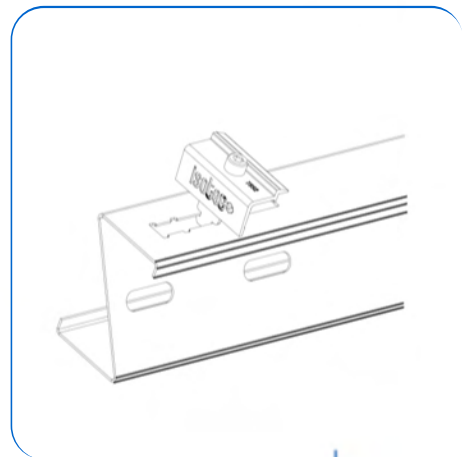
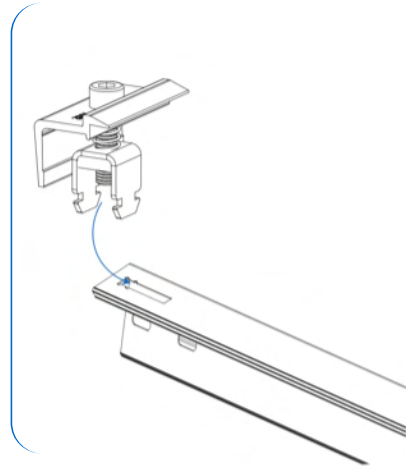
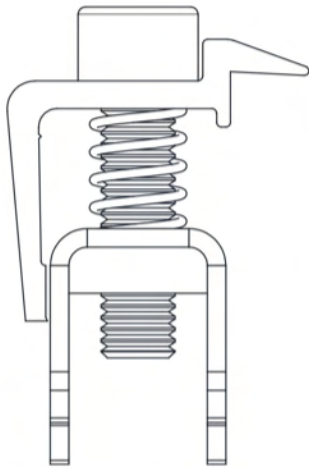

MAINTENANCE

- To maintain optimal performance yearly inspection of system should be conducted
- Inspect visually for damage, corrosion or movement. Replace any affected components immediately.
- Check mechanical details of the structure:

-At least 2% of bolted connections must be checked using a calibrated torque wrench.

The torque wrench must have a display or be a click type torque wrench.

-Torque wrench should be set at 50% of the intended tightening torque. Check is successful if the bolt cannot be loosened.

-If >10% of the checked bolted connections are loose, the check has to be increased by a factor of five.

-If more than 10% of connections are still loose, all bolted connections must be checked.

-Tighten to specified torques

-Maintenance should only be performed by qualified personnel.

-WARNING: Risk of death by electric shock

NOTES

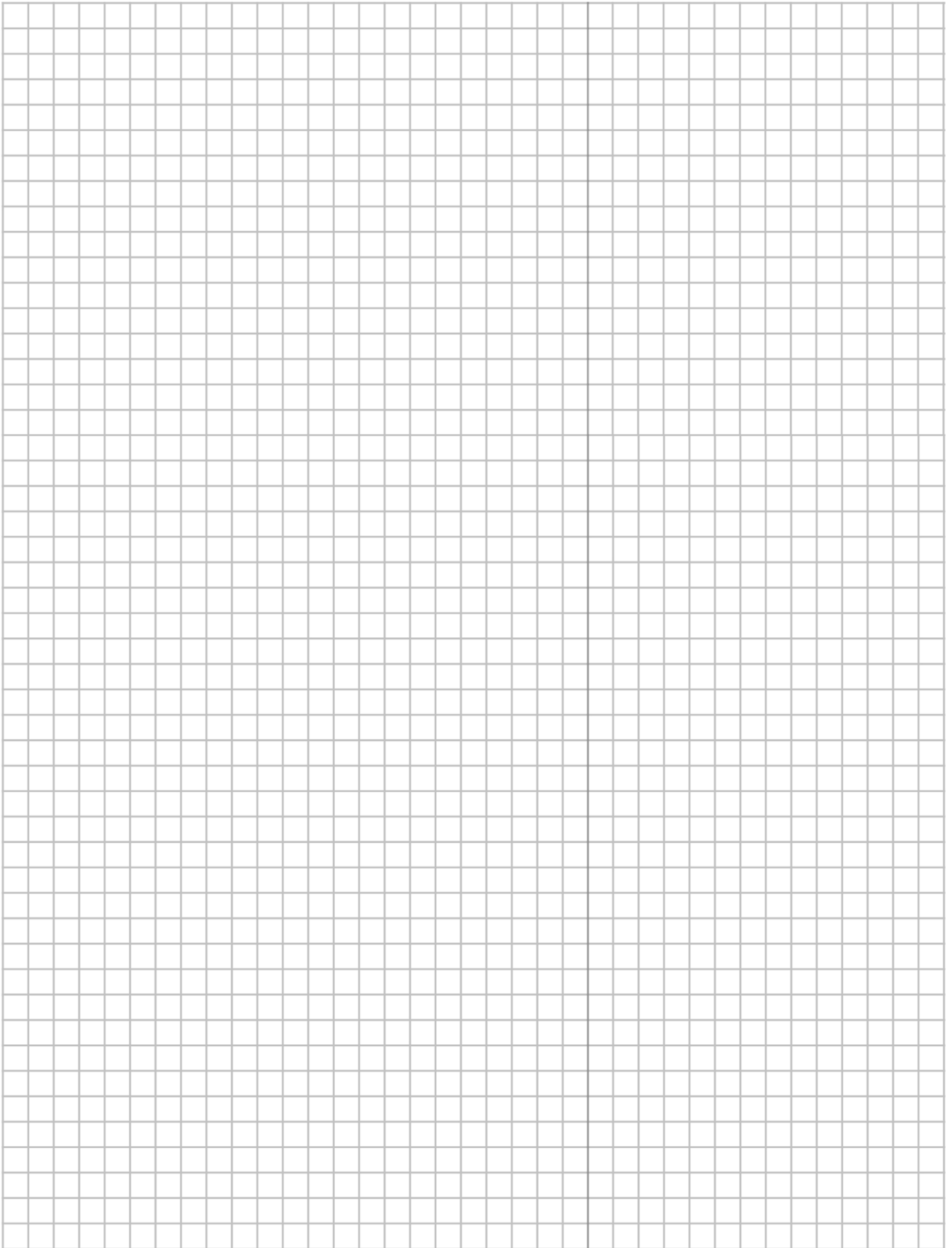

Our valued customer,

Thank you for choosing **ISOTEC** for your solar mounting system.

Your opinion is very important to us.

You can always contact us at [+90 \(262\) 244 43 09](tel:+902622444309) or info@isotec.com.tr for suggestions, feedback and all questions about assembly.

You can be informed about current developments by following us on our social accounts.

